

The methodology of testing rotational resistances of the rollers under the operation load

Piotr Kulinowski, Piotr Kasza, Jacek Zarzycki
AGH University of Science and Technology, Poland

Date of submission to the Editor: 05/2019

Date of acceptance by the Editor: 07/2019

INTRODUCTION

Belt conveyors are one of the most efficient and versatile continuous transport devices in many branches of industry. Thanks to their advantages, in many cases belt conveyors are irreplaceable in the raw material, energy or agricultural industries. Their design is being developed very rapidly through last years thanks to among others material engineering progress. New materials allows to produce more efficient components for those conveyors like belts and rollers.

The rollers and belt are the components of the conveyor that generates significant costs while exploitation. Therefore there is a need to improve current design and develop new solutions of those components.

The rollers are the most numerous sub assembly of the conveyor (Fig. 1).



Fig. 1 Overland belt conveyor

There can be over 3000 pieces of rollers per one kilometer of conveyor length. That means the conveyor energy consumption and its reliability significantly depends on the rollers quality.

The parameter that allows to evaluate the rollers quality is its rotational resistance. There are lot of factors that affects on rollers rotational resistances, like shown in Table 1. Knowledge of these resistances is important not only in the design of conveyors, but also in the improvement and search for new structural solutions of the rollers (Kulinowski 2012).

Table 1 Sources of rollers rotational resistance

Structural factors	Manufacturing factors	Exploitation factors
<ul style="list-style-type: none"> - length - axis diameter - roller diameter - coat thickness - bearing quality - type of sealing - type of grease - fit of components 	<ul style="list-style-type: none"> - machining accuracy - assembly accuracy - roller unbalance - inaccuracy in positioning the bearings - matching of parts 	<ul style="list-style-type: none"> - belt speed - load - temperature - humidity and water - dust and dirt - corrosion - location - operating times - human factor

There are standards that define the measurement method and the allowable level of rotational resistance of the rollers. But the conditions of measurement according to standards do not correspond to real operational conditions of the rollers. Those standards allows only to determine the rollers quality at the production stage.

It is very hard or even impossible to measure rotational resistances of rollers in exploitation conditions, for example underground mine. So a good solution is to conduct laboratory tests in conditions similar to real ones, like load, speed and others (Kulinowski et all, 2011).

The paper deals with unique test stand developed by the authors and an original testing methodology of rollers rotational resistance with results discussion and conclusions.

TEST STAND AND METHODOLOGY OF RESEARCH

The tests of rotational resistance of the rollers under radial force load were carried out at a unique stand developed at the Department of Machinery Engineering and Transport, AGH University of Science and Technology. The general view of the laboratory stand is shown in Fig. 2.

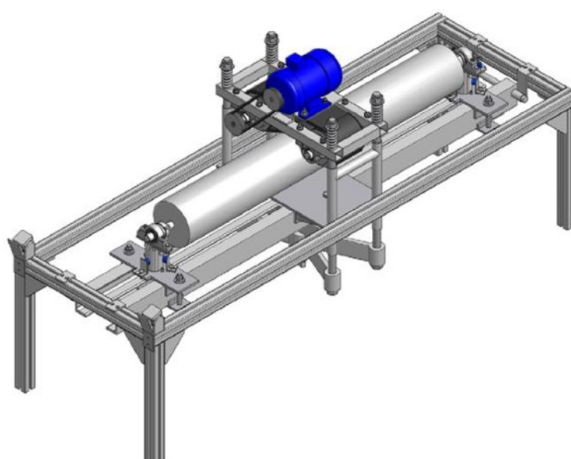

Fig. 2 Computer visualization of the laboratory stand

The laboratory stand is designed to the test of rotational resistance of the rollers under load, especially the operational load.

The idea of the measurement is that the tested roller is embedded in a rigid frame, supported in swing bearings. The drive and load is made using a high-strength toothed belt. Figure 3 shows the general idea of the measurement.

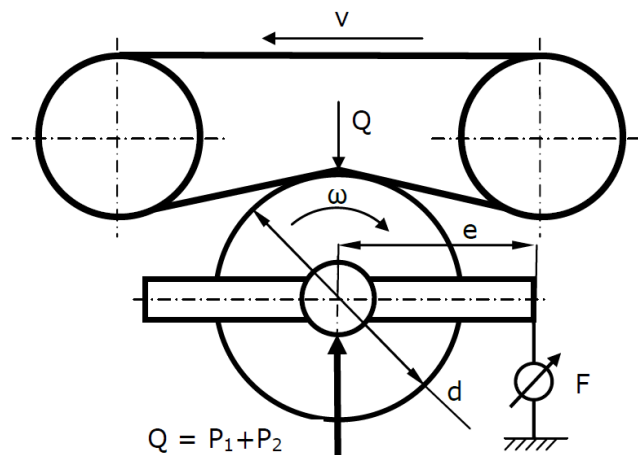

Fig. 3 Scheme of rotational resistance measurement of the roller under load where: P_1 , P_2 – reaction forces in supports

During the measurements, the reaction force F acting on the frame on the arm e and the radial force Q loading the roller as the sum of forces in both supports P_1 and P_2 are recorded.

The rolling resistance of the roller is calculated from the formula below:

$$W = \frac{F \cdot d}{2 \cdot e} [N] \quad (1)$$

where:

F – reaction force,

d – roller diameter,

e – the F force arm.

The force F is measured by a CL-17pm force sensor with a measuring range of 100 N and a total error below 0,2%. The frequency of the F force recording was 1 kHz and the accuracy of the measurement was $\pm 0,13$ N.

Figure 4 shows the roller installed on the laboratory stand. The load and drive assembly with high strength toothed belt is visible.

The laboratory stand is equipped with an advanced measuring system built into the supports, which allows measuring the forces acting on the roller. Each support has 3 strain force sensors installed radially and spaced every 120° , in such a way that one of the sensors is mounted in the axis of the roller.

To sum up, the stand is equipped with 9 strain force sensors, which allow for precise measurement of the rolling resistance of the roller, radial and axial force. All forces were recorded with the frequency of 1 kHz in the LabView data acquisition application.

During the tests of rotational resistance of the rollers the following independent variables were adopted:

- values of radial force from 250 to 1500 N,

- the peripheral speed of the roller from 1 to 5 m/s.

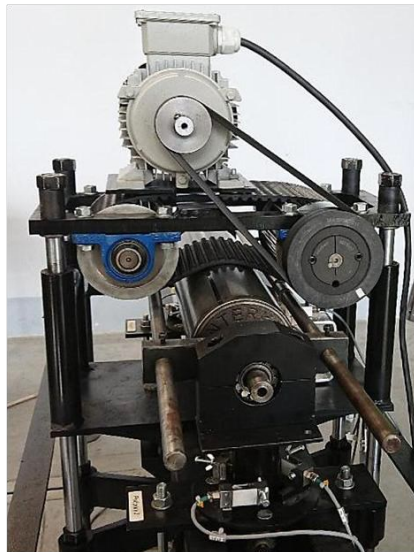

Fig. 4 View of the roller mounted on the laboratory stand

The values of the above parameters have been selected in such a way that the operating conditions in which the rollers work are mapped (Kulinowski, Kasza 2013).

All rollers were lapping in accordance with the standard requirements. Before the tests, each roller worked a minimum of 30 minutes for warming up which guaranteed repeatability of results.

Laboratory tests of the rotational resistance of roller were carried out in four series. Each of the series consisted of 5 tests which gives 20 trials for each idlers. The sample was divided into 5 time sequences lasting a total of 40 seconds. At the beginning, data recording was started, then after 5 seconds the drive of the idler was switched on and for the next 10 seconds the rotation resistance was recorded only under the radial force load. After 15 seconds, the drive of the idler was switched off and after the next 5 seconds the data logging was stopped.

As a result of the measurements, a record of the rotational resistance force of the roller's in time was obtained.

Figure 5 shows the record of the rotational resistance force in time for single attempt.

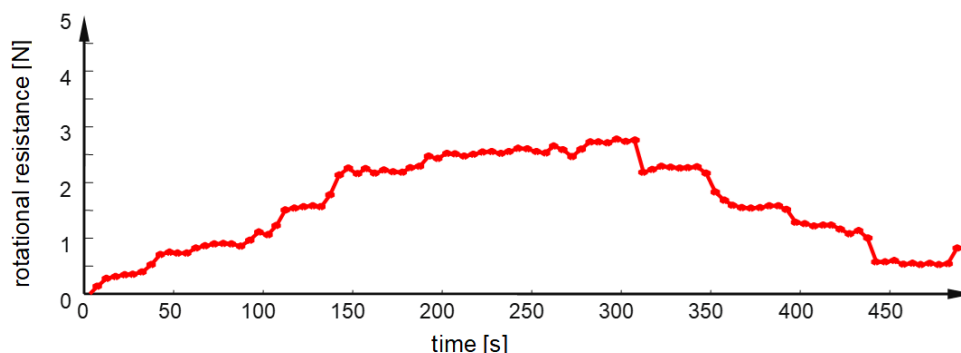

Fig. 5 The average rotational resistance force vs. time

Red line means average value of rotational resistance. During attempt lasting 500 seconds radial force was increased from 250 to 1500 N, and then decreased from 1500 to 250 N. It is visible in Figure 5. Change of radial force causes the change of rotational resistance of roller. Oscillation of measured force is also visible. It is caused by rotating parts of test stand and the roller itself.

The tests were carried out for the roller $\varnothing 133 \times 465$. It is the most common roller size in mining industry.

THE RESULTS OF THE TESTS

As a result of the tests, rotational resistance of the rollers was obtained depending on the load and speed. It is shown in Figures 6 and 7.

Chart in Figure 6 shows rotational resistance of the rollers depending on the load for three different speed. By increasing the radial load, the rotational resistances increases approximately linear. After exceeding the radial load of 1000 N the of rotational resistance stabilizes at a constant value for all three runs of 2.5, 3.5 and 4.5 m/s.

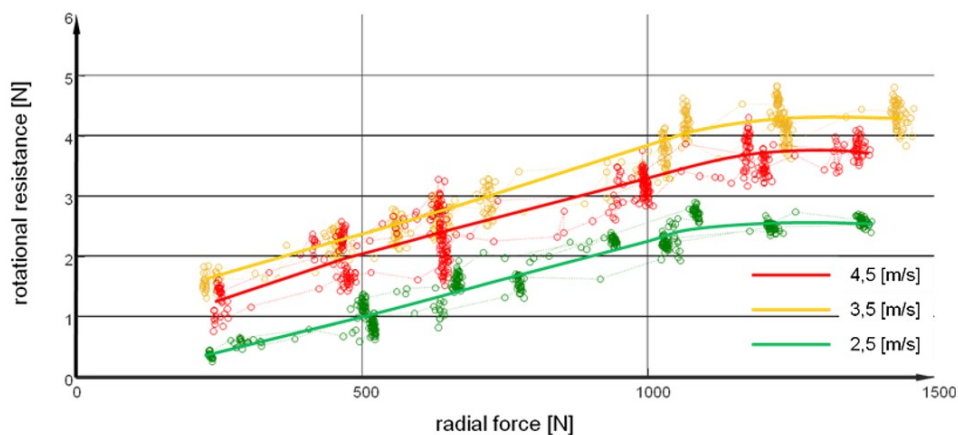

Fig. 6 Chart of rotational resistance in dependence of radial force and for different speeds

Interesting issue was observed for rotational resistance in dependence of speed. There is value of the belt speed for which rotational resistance of the roller achieves maximum and then gently decreases (Fig. 6). To confirm this trend additional tests were carried out. The additional test consisted of measurement the rotational resistance for constant radial load of 1100 N and variable speed of the roller. The roller speed was set from 1 to 5 m/s. The result is shown in Figure 7.

The left chart in Figure 7 shows the change of rotational resistance on dependence of roller speed. The maximum value of rotational resistance is at speed of approximately 4,5 m/s, which confirms above conclusions (Fig. 6). Similar trend was observed during other tests of new design of the roller (Furmanik, Kasza 2012). The authors carried out a series of tests of new design of the roller with needle bearings. The selected results is shown in Figure 8. Chart shows rotational resistance of the roller at speed from 0,5 to 5,4 m/s in ambient temperature 20°C and -20°C. It confirms that operational properties of the rollers depends mainly on the load but also the speed.

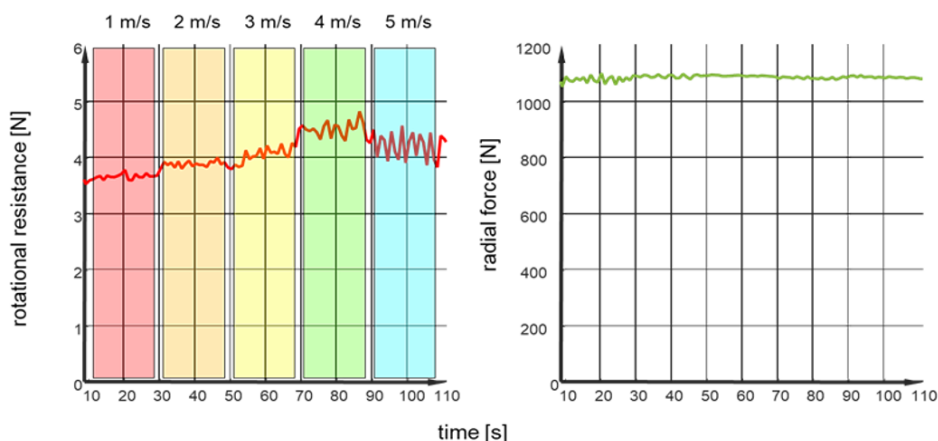

Fig. 7 Chart of rotational resistance in dependence of speed (left) and record of radial force for this attempt (right)

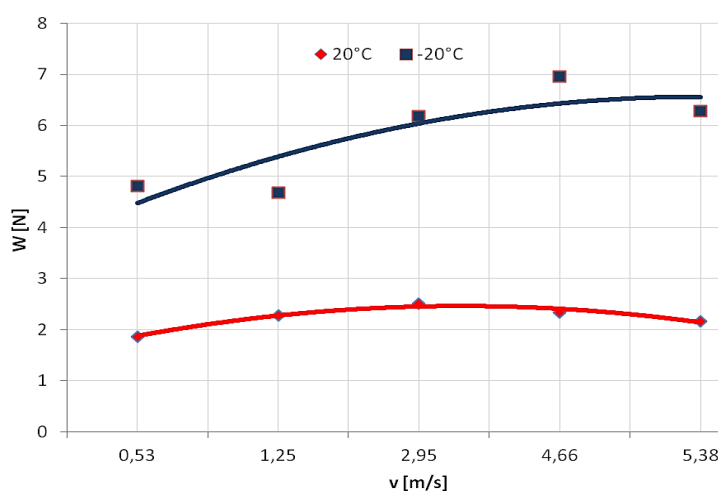

Fig. 8 Chart of rotational resistance in dependence of speed and ambient temperature
Source: (Furmanik, Kasza 2012)

CONCLUSIONS

The presented test stand allows for testing the rotational resistance of the rollers with a coat length of 250 to 1200 mm and a diameter of 89 to 219 mm. The radial load value during the test of the roller can be set from 250 N to 2000 N. Laboratory tests were carried out on a roller with a length of 465 mm and a diameter of 133 mm. The speed of rotation of the roller during the tests corresponded to the speed of the belt conveyor 1÷5 m/s.

Laboratory tests carried out allow to specify the following conclusions:

1. With increased radial load, the rotational resistance of the roller increases; eg for a radial load of 250 N, the value of the resistance of rotation of the tested roller is 0.5÷1.5 N while for a load of 1200 N, the rotational resistance increases to 2.5÷4.5 N (Fig. 6).
2. With the increase of the rotational speed of the roller, its rotation resistance increases; for example: for radial load 1200 N, rotational speed of the roller 144 rpm (speed of the belt conveyor 1 m/s), the rotational resistance of the roller is about 3.5 N, for the rotational speed of the roller 600 rpm (speed of the belt conveyor 4 m/s) the rotation resistance of the roller increases to 4.5 N (Fig. 7).

3. Rotational resistances of the rollers significantly depends on their operational load and peripheral speed. It is also necessary to indicate the difference between the standard method and the research methodology developed by the authors. Measurement of the rotational resistance according to standard is carried out at radial load of 250 N. Research carried out by the authors, shows that rotational resistance of the roller at standard load and at operational load can be greater even four times (Fig. 6). That is why there is a need to continue those research. Presented laboratory stand and the research methodology allows to test the different types of rollers in near to operational conditions. The results of further research can be used in developing of new types of rollers.

REFERENCES

- Furmanik K., Kasza P. (2012). Investigations of new design idler rolling resistances. *Transport Przemysłowy i Maszyny Robocze*. Nr 3, s. 52-55.
- Kulinowski P., Kasza P., Kozubek A. (2011) Industrial tests of idlers set load in aspect of calculation methods verification. *Przegląd Górniczy*; t. 67 nr 11, s. 92-97.
- Kulinowski P., Kasza P. (2013) Tests of carrying idlers load state in conditions of mining works. *Materiały Szkoły Eksploatacji Podziemnej Kraków, 18-22 lutego 2013*
- Kulinowski P. (2012) *Integrated design methodology for mining belt conveyors*. Kraków Wydawnictwa AGH.

Abstract.

One of the components that affects the energy consumption of belt conveyors is the rotational resistance of the rollers. In real conditions, the roller is subjected to loads not only radial but also axial, resulting from its cooperation with the belt and the way of installation on the conveyor. Knowledge of these resistances is important not only in the design of conveyors, but also in the improvement and search for new structural solutions of the rollers. The article presents an innovative stand dedicated to the study of rotational resistance of the rollers under operating load, its research capabilities and the results of preliminary tests.

Keywords: belt conveyor, roller, rotational resistances, operation load