

**Magdalena Mazur**

ORCID ID: 0000-0003-3515-8302

Czestochowa University of Technology, Poland

### INTRODUCTION

Surveying techniques are one way of researching respondents' opinions on a specific topic. The respondents are experts in the assessment of processes that are subject to surveys. The respondents' rating is their expert knowledge (from experience) and becomes the basis for general inference regarding these processes. The preparation of the survey is directly correlated with the purpose of the research and the topic raised in the survey questions. The results of the answers are subject to inference and basic statistical analyzes.

The survey was carried out in manufacturing companies. The survey concerns the use of quality management tools in manufacturing processes and manufacturing support. The article presents the results of a survey for enterprises that produce PVC windows. Preliminary analysis of the surveys allowed the selection of research materials of enterprises working in mass and mass production mode. The survey responses received concern manufacturing plants and were initially limited to companies from the window industry (Barosz P. et al. 2018, Dziuba Sz., et al. 2016). The prepared survey includes guidelines for issues related to various quality management tools and their short characteristics, so that respondents consider questions in the same way. The questionnaires were directed to employees holding managerial positions in the field of production preparation, implementation of technological processes and logistic implementation of support staff. The questionnaires were completed in electronic form by employees who are managers and grouped for individual production plants (or their branches).

The main purpose of the prepared survey was to learn about the use of available quality management tools directly on the production line in various production plants. The entire survey will indicate the range of universal tools that are used in companies regardless of the industry, and define examples of solutions dedicated to individual eviction processes (Czerwińska K., Pacana A., 2019; Knop K. 2019; Rosak-Szyrocka J., Knop K. 2018).

## BASIC STAGES OF PVC WINDOW PRODUCTION

Differentiation in series production concerns on dimensions for a particular window model. Preparation of the window frame using various profiles and assembly of insulating glass for preparation of the window frame. Completing the finished product also includes the implementation of the window frame as part of the window assembly and product functionality.

The basis for cooperation in the field of completing the survey was cooperation in qualitative analyzes of the mold production process from Dąbrowa Górnicza. Qualitative analyzes of processes included the characteristics of the production stages and production non-compliance arising in them. The elaboration of the decomposition of the production system allows for a more precise analysis of production, detection of the potential place of where incompatibilities were formed and prevention of their formation (Kuchariková L. et al. 2016). The production system from a technological point of view has been presented in Fig. 1.

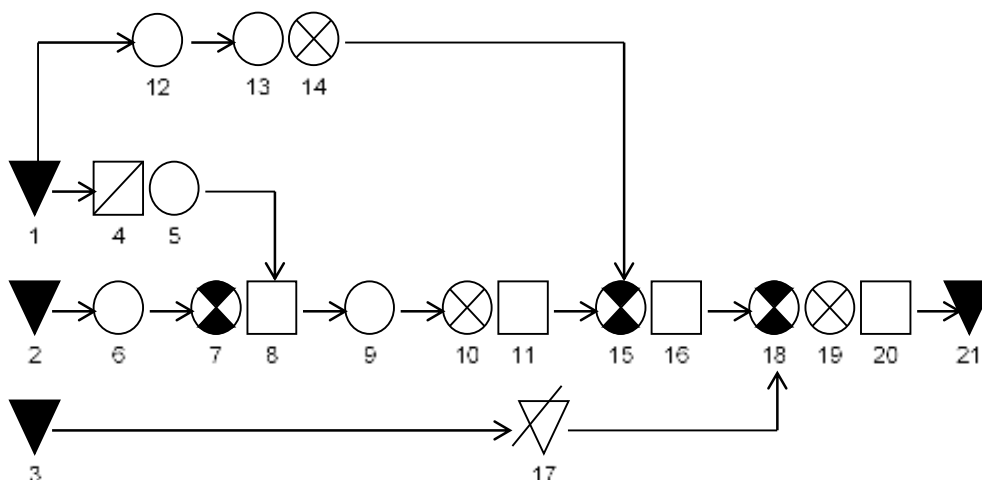

**Fig. 1** Process of producing a single chamber window in a technological quantification

The clarification of the figures provided in Fig. 1 signify the following operations: 1 - storage of PVC profiles, 2 - storage of aluminium racks, 3 - storage of panes, 4 - preliminary check of the quality of the PVC profile, 5 - appropriate machining that involves the cutting of profiles into dimensions, 6 - the cutting of racks into dimensions, 7 - operation of assembling the profile with the racks, 8 - inter-operational check, 9 - welding of wings of the window on the four-headed welder, 10 - machining in the completion of the wings (removal of excess heated material), 11 - inter-operational check, 12 - cutting of frame into dimensions, 13 - welding of frame on the two-headed welder, 14 - machining in the completion of frames (removal of excess material, sealing), 15 - operation of fitting (frame + wing + fixtures), 16 - inter-operational check, 17 - periodic storage of glass panes, 18 - fitting of glass panes, 19 - cleaning, 20 - final check, 21 - storage of finished goods.

### QUALITATIVE ANALYSIS OF MANUFACTURING PROCESSES

#### Area of formation of incompatibilities – Ishikawa diagram

The results of the analysis in the form of the Ishikawa diagram has been presented in Fig. 2. The Ishikawa diagram was created with the use of the principles of the 5M, which state that the production of the most important group of factors that have an impact on the quality of goods include the following: manpower, method, machine, material, management (Nowacki R., et al. 2017).

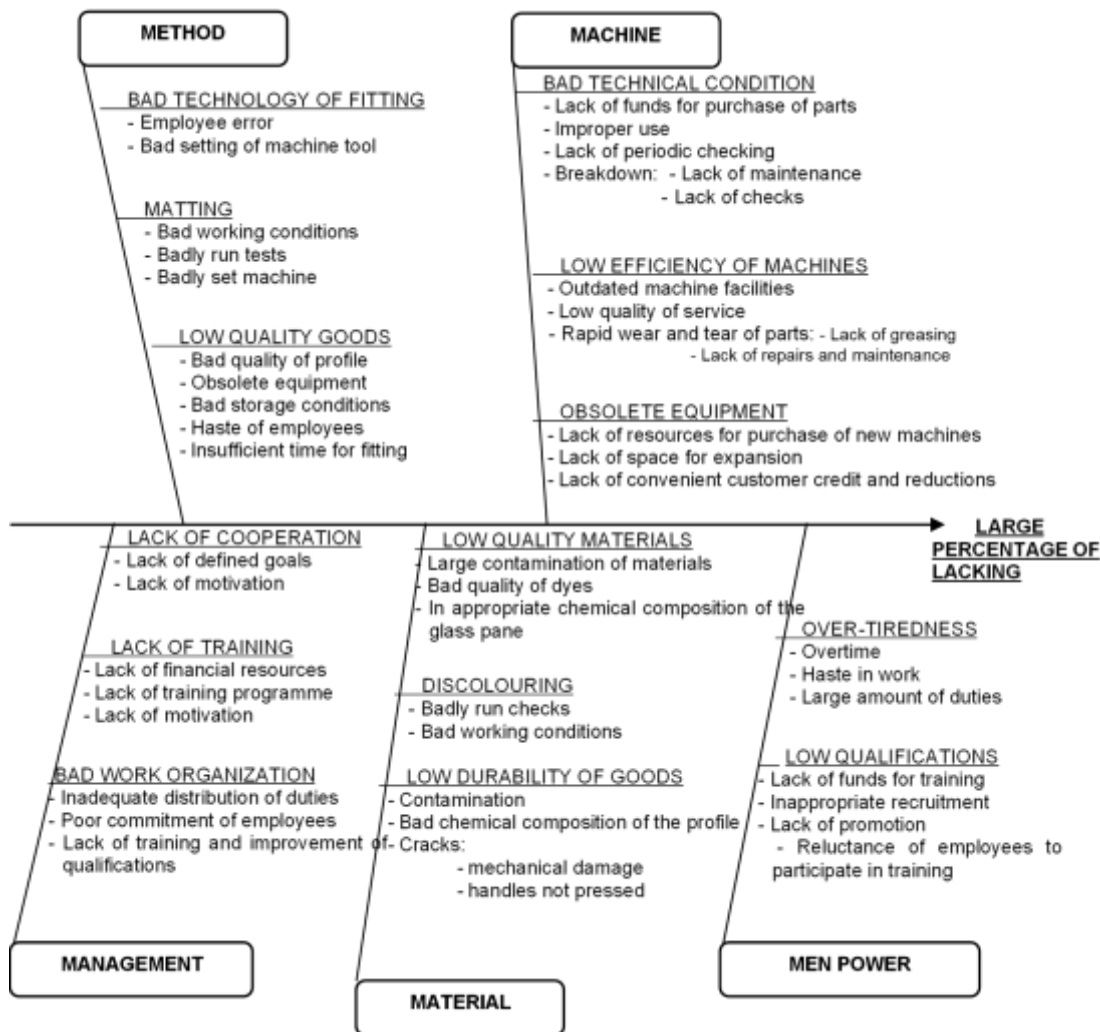

Fig. 2 Ishikawa graph for the issue of the production process of PVC windows

The data for the Ishikawa diagram was gained with the aid of interviews run with the blue collar workers and the management of the company. During the analysis, it was stated that the most frequently recurring element that indicates one of the reasons for the large amount of incompatibilities in production is the lack of an efficient maintenance of the movement which leads to the rapid wear and tear of the machines.

### Quarterly list of incompatibilities in single chamber windows – the Pareto-Lorenzo diagram

The data for the Pareto-Lorenzo diagram comes from the quality control department where 10 types of incompatibility were identified, which have been listed in Table 1.

**Table 1 List of incompatibilities and their proportion**

Symbol	Name of incompatibility	Frequency [pcs]	Proportion [%]	Accumulated proportion [%]
N 1	Blocking of handles	241	30.98	30.98
N 2	Damage	153	19.67	50.64
N 3	Inappropriate technology of fitting	115	14.78	65.42
N 4	Low quality of material	84	10.80	76.22
N 5	Damaged sealants	63	8.10	84.32
N 6	Corroded metal elements	42	5.40	89.72
N 7	Breakage	33	4.24	93.96
N 8	Non-conformity with the dimensions	21	2.70	96.66
N 9	Defects	15	1.93	98.59
N 10	Cracks	11	1.41	100

Source: own study

The initial data gained from calculating the values of proportion and accumulated proportions (Ulewicz R., Novy F., 2019) has been displayed in Fig. 3.

As a result of the analysis in Fig. 3, the following incompatibilities were stated: blocking of handles (N1), damage (N2), inappropriate technology of fitting (N3), low quality (N4) which constitutes a combined total of 40% of all incompatibilities that are responsible for 76.22% of all existing complaints.

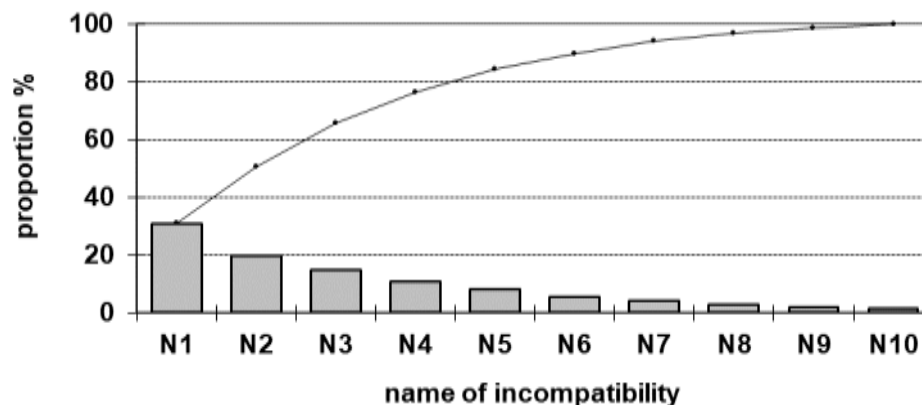

**Fig. 3 Pareto-Lorenzo graph for incompatibilities in single chamber windows**

Quantification of the reasons for the incompatibilities on the basis of the FMEA method as described in Table 2.

Table 2 FMEA datasheet for incompatibilities in single chamber windows

Type of incompatibility	Reason	Effect	DET	OCC	SEV	RPN	Corrective action	DET	OCC	SEV	RPN
Blocking of handles	Improperly matched dimensions of the profile	Problems with opening and closing the window	7	2	6	84	Regulation of parameters for fitting	5	1	6	30
Damage	Employee error in setting the machine	Lack of safeguards against external factors	6	7	5	210	Additional training in use of machines	4	3	5	60
Inappropriate technique of fitting	Bad setting of the machining tool	Stalling the production process	8	1	5	40	Training referring to work positions for employees	7	1	5	35
Low quality material	Bad storage conditions	External stresses in the profile	4	1	8	32	Supervision of conditions for storing raw materials	2	1	8	16
Damaged sealants	Bad chemical composition of sealants	Problems with fitting, bad airflow and micro-ventilation of the window	6	4	7	168	Tightening control on suppliers	4	1	7	28
Corroded metal elements	Defective material	Greater resistance when opening the window	2	7	6	84	Exchange for stainless steel elements	1	4	6	24
Breakage	Haste and absent-mindedness of employees	Prolonging the deadline for realizing the order	7	4	7	196	Increasing the freedom of employees and additional training	2	3	7	42
Non-conformity with the dimensions	Badly run preliminary checks	Complaints and claims	5	3	4	60	Tightening conditions of checking	2	3	4	24
Defects	Lack of adjustment of work position	Impurities between the panes	7	4	5	140	Implementing the practices of 5S	2	4	5	40
Cracks	Mechanical damage during transportation	Necessity of exchanging the glass panes	6	1	6	36	Additional protection of windows during transportation	4	1	6	24

Source: own study

Eliminating the reason for the existence of the four most frequent incompatibilities could lead to a reduction in complaints by a maximum of 76.22%. The remaining 6 incompatibilities which constitute 60% of all incompatibilities are responsible for only 23.78%. In defining the corrective action of the most frequent incompatibilities the FMEA test has been worked out, which specifies the level of risk of producing goods that are not in conformity (Siwiec D., Pacana A. 2019; Stamatias D.H 2003; Wolniak R. 2019).

On the basis of the structure of incompatibilities gained from analyzing the Pareto-Lorenzo diagram and also analysis of the decomposition of the production system calculated on the FMEA datasheet for these incompatibilities. The proposed corrective action in the analysis caused a drop in RPN in all cases, which goes to prove that these actions brought measurable effects in the form of reducing the appearance of incompatibilities, or improved the ability to detect them while still in the production line.

## **MATRIX OF QUALITY MANAGEMENT TOOLS IN MANUFACTURING PROCESSES**

### **Set of available quality management tools**

Quality requirements for products require producers to collect information during the manufacturing process. For this reason, the collected quantitative and qualitative data, which relate to the quality of individual processes, become the basis for qualitative analyzes in the process. Manufacturers can use various tools in this area, which are selected according to the demand for quantitative data for analysis and due to the resulting data (Zasadzień M. 2016). The resulting data are the basis for inferring the quality of manufactured products. Among the many solutions that deal with the analysis of quantitative data from processes, it is necessary to choose the right tools and determine their suitability for individual processes. Depending on the implemented quality assurance systems in the enterprise, product manufacturing processes require collection (registration) and analysis of quality data. Then these data are used for qualitative analyzes and improvement of production processes using e.g. Deming Circle. The Deming Circle is the basis for improvement, both in terms of process and position. To achieve improvement of implemented processes, reliable data and appropriate analyzes should be provided. To provide the data necessary for analysis, it must be selected the right tools, both for collecting and then processing this data (Kuchariková L. et al. 2016; Nowacki R., et al. 2017; Sałek R., Klimecka-Tatar D. 2016).

All stages of preparation and implementation, and then supervision of manufacturing processes require the use of appropriate tools (Siwiec D., Pacana A. 2019; Stasiak-Betlejewska R., Czajkowska A. 2016). Information about the use of quality management tools at individual stages in window production is shown in Figure 4. The figure quantitatively includes which tools were most often indicated as useful in analyzes. The presented results relate to enterprises only in the field of window production and window profiles, the

production of insulated glass is not included (Ulewicz R. 2013; Ulewicz R. 2018). Respondents indicated which tools are used at particular stages of production and analysis. The results obtained mean: 1 - very rarely or not at all, 2 - often, 3 - very often

stages of qualitative analysis in the manufacturing process	Tools and methods											
	DoE	FMEA	QFD	Correlation diagram	SCP	Histogram	Parto-Lorenz diagram	Ishikawa diagram	Flow Scheme	Brainstorming	control sheets	Kaizen
definition of the problem	3	3	2	3	1	2	3	3	3	3	3	1
collecting data	1	2	1	3	2	2	2	2	2	2	3	1
analysis of the available data	2	3	1	1	3	3	1	1	1	2	2	3
formulation of assumptions in the analysis	1	1	2	1	1	1	3	1	3	3	1	3
verification of assumptions in the analysis	2	1	2	1	1	2	1	2	2	2	1	2
identification the cause of the problem	2	2	1	3	2	1	3	3	1	1	3	2
defining the solution	2	3	1	3	1	1	2	3	1	3	2	1
solution planning	1	2	1	3	1	1	1	2	3	2	1	1
implementation of solutions	2	3	1	1	1	1	1	2	1	1	1	2
monitoring	1	2	1	2	3	3	2	1	1	1	3	2

Fig. 4 Frequency of use of selected tools and methods

The matrix of familiarity and the use of individual tools in qualitative analyzes for inductive processes indicated that each of these tools are used. The largest number of tools is focused on identifying and detecting quality problems. The widest application can be seen for FMEA analysis and correlation diagram, which are used in a wide range of qualitative analyzes and solution planning.

**The importance of quality management tools in company structures**

The overall survey results show how companies know and use individual quality management tools. Figure 5 presents survey indications for individual tools in relation to the size of the enterprise. Figure 5a shows the results for small and medium-sized companies, Figure 5b is the results for large companies. This data has not been limited to the window production industry, but applies to all companies in which the survey was conducted. The importance of using individual tools was also assessed according to Severiti Rating guidelines. This assessment is to determine the frequency for using tool and also weight for the data.

Figure 5 presents the results of indicating individual tools as useful (used in the enterprise) and were compared with the Severity Rating indicator for the same enterprises.

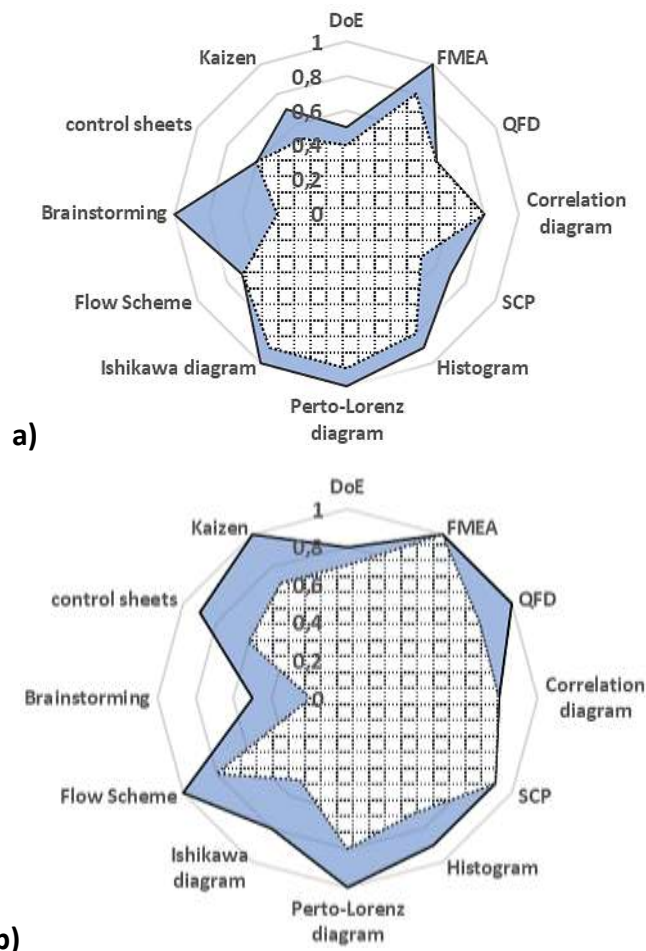

**Fig. 5 Indicators of the importance of quality management tools for companies: a) small and medium, b) large**

The difference indicated in this estimation is the result of a detailed estimation of the processes that use the tools. This underlines the importance of tools in company structures and the use of results.

Small and medium enterprises all indicated the use of the tools: FMEA, Ishikawa diagram, Pareto-Lorenz diagram and brainstorming. In these cases the utilization rate was 100%. However, Severity Rating for these tools was slightly lower, Only Brainstorm was rated much lower in Severity Rating and was only 0.4. It is interesting that for four tools (control sheets, QFD, correlation diagram and flow scheme), the utilization rate and Severity Rating received the same grades.

In the group of large companies, the Kaizen philosophy has gained in importance, which next to: FMEA, the Pareto-Lorenz diagram, QFD and Flow Scheme received a 100% utilization rate (all companies indicated these tools as used in qualitative analyzes). This result was confirmed only in the case of FMEA, which Severity Rating was estimated at level 1. The Corel diagram and SPC received the same values in this two ratings.



## CONCLUSION

The analysis presented in this paper availed of two classic tools of quality management: the Ishikawa diagram and the Pareto-Lorenzo diagram. The application of these tools indicated a quantitative level of incompatibilities, as well as enabling the necessity of defining their reasons. Subsequently, the application of the FMEA test indicated the undertaking of corrective action, concentrating mainly on running additional training for employees, as well as increasing the intensity of checks and supervision of the process.

Comparison of results for individual tools in terms of their use and Severity Rating showed differences in perception for subsequent quality management tools. Calculations confirmed the importance and use of data for tools for: correlation diagram, FMEA, Flow Scheme and QFD analysis. The received surveys confirmed the numerous use of quality management tools, both in the implementation of manufacturing processes and in solving quality problems in the process. Differences in the use of individual tools and Severity Rating were estimated and indicated.

## REFERENCES

- Barosz P., Dudek-Burlikowska M., Roszak M. (2018) The application of the FMEA method in the selected production process of a company, *Production Engineering Archives* 18, pp. 35-41.
- Czerwińska K., Pacana A., (2019) Analysis of the implementation of the identification system for directly marked parts – datamatrix code. *Production Engineering Archives* 23, pp. 22-26.
- Dziuba Sz., Ingaldi M., Kadłubek M. (2016) Use of Quality Management Tools for Evaluation of the Products' Quality in Global Economy. *Globalization and Its Socio-Economic Consequences, 16<sup>th</sup> International Scientific Conference Proceedings, PTS I-V, 2016*, pp. 425-432.
- Knop K. (2019) Elimination of constraints in the production process of power equipment components and the analysis of the resulting benefits. *Production Engineering Archives* 24, pp. 37-42.
- Kuchariková L., Tillová E., Závodská D. (2016) The assessment of castings quality using selected quantitative methods. *Production Engineering Archives*, vol. 13, pp. 7-10.
- Nowacki R., Szopiński T.S., Bachnik K. (2017) Determinants of assessing the quality of advertising services. The perspective of enterprises active and inactive in advertising. *Journal of Business Research* 88, pp. 474-480.
- Rosak-Szyrocka J., Knop K. (2018) Quality improvement in the production company. *MAPE* 2018, vol. 1, issue 1, pp. 521-527.
- Sałek R., Klimecka-Tatar D. (2016) Management and controlling of stocks in the supply chain of metallurgical industry. *METAL 2016: 25<sup>th</sup> International Conference on Metallurgy and Materials*. Brno, pp. 1993-2000.
- Siwec D., Pacana A. (2019) The use of quality management techniques to analyse the cluster of porosities on the turbine outlet nozzle. *Production Engineering Archives* 24, pp. 33-36.
- Stamatis D.H (2003) Failure mode and effects analysis: FMEA from theory to execution. *American Society for Quality (ASQ)*.
- Stasiak-Betlejewska R., Czajkowska A. (2016) Quantification of the Quality Problems in the Construction Machinery Production. *9<sup>th</sup> International Conference on*

- Computing and Solutions in Manufacturing Engineering. Brasov, Romania: CoSME'16, 3-4 November 2016.
- Ulewicz R. (2013) Quality control system in production of the castings from spheroid cast iron", *Metalurgija*, 42, pp. 61-63.
- Ulewicz R. (2018) Outsourcing quality control in the automotive industry. MATEC Web Conf., 183, 12th International Conference Quality Production Improvement – QPI 2018, MATEC Web of Conferences [on-line:] [https://www.researchgate.net/publication/326712268\\_Outourcing\\_quality\\_control\\_in\\_the\\_automotive\\_industry](https://www.researchgate.net/publication/326712268_Outourcing_quality_control_in_the_automotive_industry)
- Ulewicz R., Novy F., (2019) Quality management systems in special processes. *Transportation Research Procedia* Vol. 40, pp. 113-118.
- Wolniak R. (2019) Problems of use of FMEA method in industrial enterprise", *Production Engineering Archives* 23, pp. 12-17.
- Zasadzień M. (2016) Optimization of the soldering process by the DMAIC methodology. *Production Engineering Archives* vol. 11, pp. 6-10.

**Abstract:** The article presents the results of research analyzing the level of use of quality assurance instruments. The use of quality management instruments refers to the production of windows based on PVC profiles. Based on the results of surveys, which were additionally verified by an extended expert interview, an analysis was made of the level of use of quality assurance instruments at individual stages of the technological process. The main conclusion of the analyzes is that the most commonly used quality instruments are Pareto-Lorenz analysis, Ishikawa diagram, control cards and the FMEA method.

**Keywords:** quality tools, quality methods, PCV profile, window