

Dr Andrzej Nowrot

Dr Barbara Solecka

Silesian University of Technology, **Poland**

Abstract: During the semiconductor or graphene wafers surface were investigated, the Arduino module was applied to control the impact point of the laser beam. While the pulse signal of laser beam impacts to surface selected material and the material is exposed to enough strong magnetic field, the photomagnetolectric effect takes place. This causes the electrical signal in the measurement coil, which is connected to amplifiers. The paper presents application of Arduino UNO module to control the position in two dimensions (in the XY plane) of investigated silicon or graphene wafers while the photomagnetolectric effect is measuring. The Arduino drive (through the integrated circuit with power transistors) the steps and shift of a dedicated table with a sample situated at the top of the table. Constructed equipment, based on Arduino board, allows for one step size of 1.25 μm in X-axis and Y-axis, and in effect, the each square millimeter contains 640000 measurement points. We are able also to modify the Arduino program for motors controller any moment. Moreover, it is also possible to apply the obtain method to investigate another semiconductor materials. The commercially available similar devices don't have all need functions and they are incomparably more expensive.

Keywords: Control systems, Arduino, Photomagnetolectric effect

1. INTRODUCTION

Conducting scientific research in field of physics, chemistry, biology and related sciences require generally large financial outlays. The main fraction of this cost is variety scientific equipment. Very interesting in many researches is application a simple microcontroller based on Arduino board. The Arduino in short is a mini computer – it is electronics board consists microprocessor, voltage stabilizer for power supply, USB converter (UART – USB), digital output pins (high logic level 5 V or 3.3 V and low logic level less than 0.1 V), analog output pins (depending on the version) and analog input pins. Arduino is ease to work with and it does not need an operational system. It is an open-source platform used for building electronics projects. It is programmed in c language using dedicated IDE software (Integrated Development Environment) that runs on PC computer or laptop. The board is programming directly via USB standard cable and internal Arduino bootloader – a programmer unit is not require. Many versions of Arduino exist. The simplest are the UNO and the Leonardo and the most advanced is the Due (based on ARM processor). Arduino boards have very wide range of scientific applications - especially in field of physics. It's exemplary useful in nuclear physics and medicine research (Sereno et al., 2015; Kimmling and Hoffmann, 2017; Puente et al., 2017). We applied Arduino UNO board to investigate the photomagnetolectric in surface of the semiconductor or graphene wafers. The UNO were used to drive (through the integrated circuit with power transistors) the steps and shift of a dedicated table with a sample situated at the top of the measurement table. Thanks to this solution the position of the impact point of the laser beam is precision controlled.

The Arduino UNO based on the 8-bit AVR ATmega328P microprocessor. It has 6-channels analog input with 10-bit resolution Analog to Digital Converter (ADC), 14 digital input/output pins, flash memory 32 KB and a 16 MHz quartz crystal (Atmel, 2016; Arduino, 2018).

2. METHODOLOGY OF RESEARCH

The measurement setup consists of dedicated table with the sliding measurement table with a strong magnet and the table base, the table controller based on Arduino, the laser diode with diffractive lens, a laser driver produces pulse signal and coil amplifiers with selective filters. The above system is controlled by a PC computer. There are two high precision stepper motors Sanyo SH1601-5240 on the table. Each motor does 400 steps for a one rotation.

The table controller (Fig. 1) has two stepper motor controllers (for motor 1 and motor 2), dedicated power supply unit with 5V DC output to supply the Arduino and 9V / 14V DC output driven by Arduino, resistors R with parallel switches (SW1, SW2 on Fig. 1) allowing to short resistors terminals. The switches SW1, SW2 are driven (through BD135 transistors) by Arduino. The typical motor driven usually based on connection the microcontroller to motor controller only. We used much more developed system. The know-how of table controller work is a sequence of simultaneously driving of DRV8825 controllers, supply voltage (9V or 14V) and switches settings on the resistors.

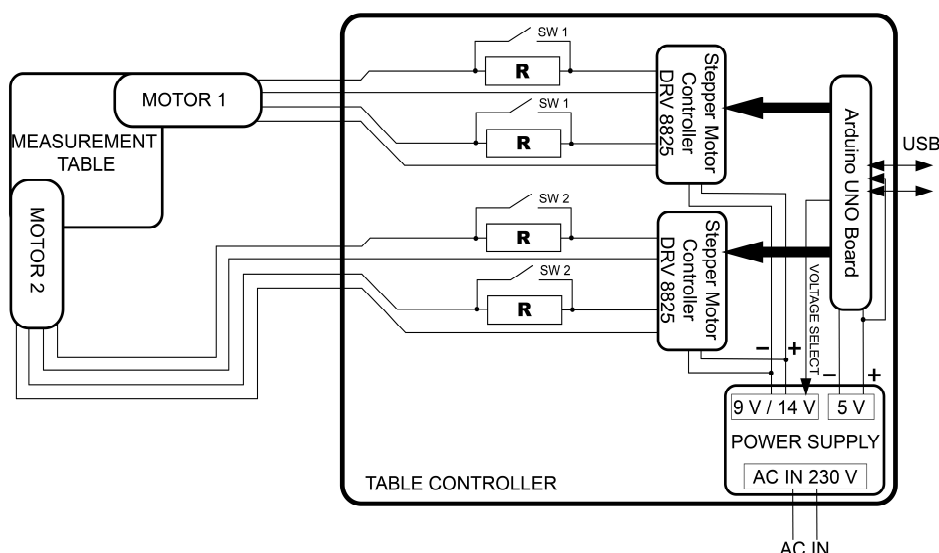

Fig. 1. The simplified schematic of table controller based on Arduino UNO

In effect, the motors have a high moment of strength when they need it and the power dissipated (emitted heat by motors) is very low. The figures 2 and 3 show the view of dedicated table system. The each stepper motor is connected to micrometer screw. Thanks to high precision motors and the micrometer screw, presented equipment allows for one step size (one full step without microstepping) of 1.25 μm in X-axis and Y-axis, and in effect, the each square millimeter contains 640000 measurement points.

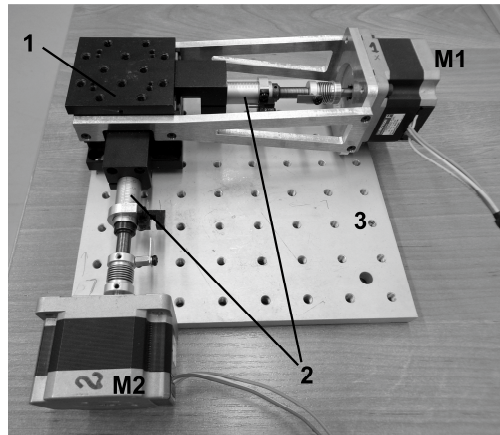

Fig. 2. The dedicated table system to measuring photomagnetolectric effect. 1 – sliding measurement table, 2 – micrometer screws, 3 – table base, M1 – X-axis stepper motor, M2 – Y-axis stepper motor

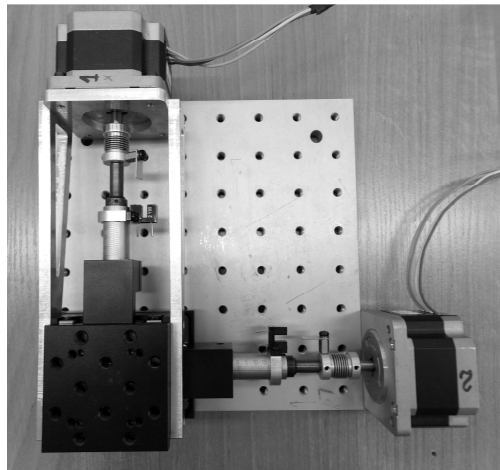

Fig. 3. Top view of table system from the Fig. 2

The figure 4 shows the structure of movable element of dedicated table system. The magnet on the top-sliding table provide constant magnetic flux density of 0.45 T. The laser source with its diffractive lens is independently situated of 10 centimeters above the surface of investigated material. The 830 nm wavelength laser beam diameter is 25 μm . The laser light is modulated at frequency of several dozen kHz - typical at 78 kHz, where the measurement coil has resonance.

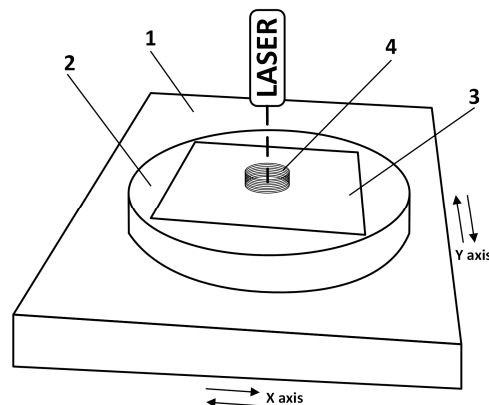

Fig. 4. the movable element of dedicated table system. 1 - sliding table, 2 - a magnet, 3 - investigated material, 4 - measurement coil

There is an external view of table controller based on Arduino UNO on the figure 5. There are 8 connectors to motor cables on the front panel.

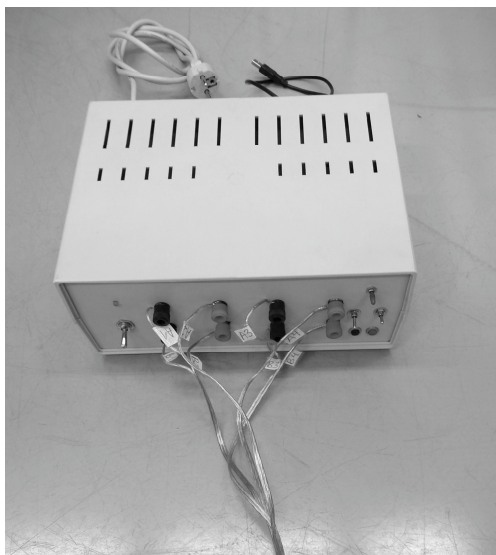

Fig. 5. The view of the table controller based on Arduino

3. RESULTS

While the temperature of all semiconductors is more than absolute zero (0 K), in short, the valence electrons are (randomly and according to rights of quantum physics) excited to conduction band. There is also a random recombination process while electrons come back to valence band in semiconductor. During the modulated intensity laser beam of diameter of 25 μm impacts to horizontal surface of investigated semiconductor material placed in the constant vertical oriented magnetic field of magnetic flux density of 0.45 T, the photomagnetolectric effect takes place. There are two simultaneously and competitive mechanisms - thermal excitation of electrons and photoconductivity. The much more information in field of physics of photomagnetolectric phenomena are in works (Kończak and Nowak, 1979; Nowak, 1987; Nowak et al., 2014; Volkov et al., 2018).

When the electrons in the place of laser beam impact are intensively excited to conduction band and they move around circles in the plane of wafer which is caused by the magnetic field (perpendicular to the wafer plane). The moving around electrons make eddy current in investigated material and the next they produce additional magnetic field. Because, the laser light is modulated, the eddy current and additional magnetic field are not constant, they are alternating. This alternating magnetic field induces electromotive force in the measurement coil. The induced voltage is amplified in the dedicated amplifiers with band filters. It should be noted, the frequency of signal of 78 kHz received in the coil comes only from the small area of diameter of 25 μm where the laser beam impacts, despite the coil diameter is 8 millimeters. The unilluminated area of the sample inside the coil does not produce 78 kHz signal, it produces wide band noise only.

The figure 6 presents the coil voltage diagram for measuring points inside the selected square silicon wafer of area size of 200 μm x 200 μm .

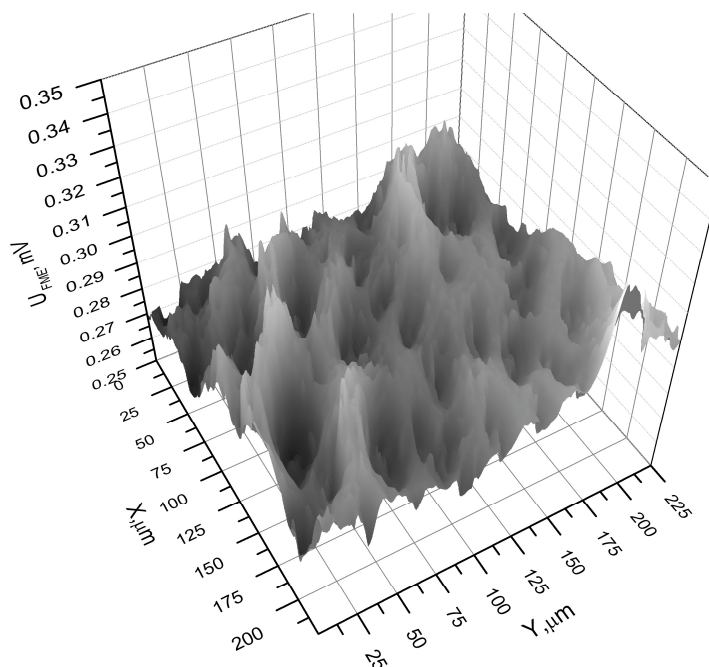

Fig. 6. The coil voltage U_{FME} diagram for measuring points inside the square selected area size of $200\ \mu\text{m} \times 200\ \mu\text{m}$. Investigated material: silicon wafer with textured structure

The results on figure 6 shows clearly the textured silicon surfaces and they very good correspond to microscope image. The textured structure of silicon wafer is well-known in surface physics.

4. CONCLUSION

The results indicate the Arduino board may be useful to research in surface physics. We constructed equipment, driven by Arduino board. It allows for one step size of $1.25\ \mu\text{m}$ in X-axis and Y-axis (one full step without microstepping). The each square millimeter contains 640000 measurement points. If the microstepping is applied the numbers of points increase four times. Getting more resolution is not possible because of the mechanism accuracy. The results obtained with constructed equipment good correspond to microscope image and the photomagnetolectric provide new material data, which are invisible microscope technique. The Arduino program for motors controller is able to modified any time. Moreover, it is also possible to apply the obtain method to investigate surface of another semiconductor materials. The commercially available similar devices don't have all need functions and they are incomparably more expensive. Proposed solution of the Arduino module is useful not only for semiconductor materials but also to photosensitive material.

REFERENCES

- Arduino, (2018). Arduino official online store. [online] Available at: <https://store.arduino.cc/arduino-uno-rev3> [Accessed 30 Apr. 2018].
- Atmel, (2016). 8-bit AVR Microcontrollers: ATmega328/P – Datasheet. [online] Available at: http://ww1.microchip.com/downloads/en/DeviceDoc/Atmel-42735-8-bit-AVR-Microcontroller-ATmega328-328P_Datasheet.pdf [Accessed 30 Apr. 2018].
- Kimmling, M. and Hoffmann, S. (2017). Influence of PV-powered thermoelectric surfaces for user-individual radiative cooling on the cooling energy demand of buildings. *Energy Procedia*, 132, pp. 15–20.
- Kończak, S. and Nowak, M. (1979). Some comments on the photomagnetolectric effect. *Surface Science*, Volume 87(1), pp. 228–238.
- Nowak, M. (1987). Photoelectromagnetic effect in semiconductors and its applications. *Progress in Quantum Electronics*, 11(3-4), pp. 205–346.
- Nowak, M., Solecka, B., Jesionek, M. (2014). Photoelectromagnetic Investigations of Graphene. *Acta Physica Polonica A*, 126(5), pp. 1104–1106.

- Puente, S. T., Úbeda, A., Torres, F. (2017). e-Health: Biomedical instrumentation with Arduino. IFAC Papers OnLine, 50(1), pp. 9156–9161.
- Sereno, M., Lupone, S., Debiossac, M., Kalashnyk, N., Roncin, P. (2015). Active correction of the tilt angle of the surface plane with respect to the rotation axis during azimuthal scan. Nuclear Instruments and Methods in Physics Research B, 382, pp. 123–126.
- Volkov, N. V., Rautskii, M. V., Tarasov, A. S., Yakovlev, I. A., Bondarev, I. A., Lukyanenko, A. V., Varnakov, S. N., Ovchinnikov, S. G. (2018). Magnetic field-driven lateral photovoltaic effect in the Fe/SiO₂/p-Si hybrid structure with the Schottky barrier. Physica E: Low-dimensional Systems and Nanostructures, Volume 101, pp. 201–207.