



**DEVELOPMENT OF AN INTEGRATED APPROACH
OF QUALITY MANAGEMENT IN DIFFICULT TECHNICAL PROCESSES**

Victor NORDIN
Kaliningrad State Technical University
Pavel SHCHERBAN
Baltic Federal University of I. Kant

Abstract:

The article presents the results of studies conducted in a company manufacturing aluminium forgings for the automotive industry. The aim of the research was to identify the defects which form during the production process as well as the locations and causes of their occurrence. Selected quality management tools were used in the process. Based on the FMEA and the costs generated by the identified defects, a hierarchy of them was created for the company along with a proposal of improvements in case of the most significant ones in order to reduce their number and increase the detection efficiency.

Key words: *methods of quality control, technical processes, technical risk assessment qualimetric*

INTRODUCTION

In modern world no one could reappraisal necessity of making reliable mode of control and quality management of different technological processes (no matter of it's destination), because various disparities in any technological process bring complex of technical, financial and ecological risks. That is why such approach was worked out and included three consecutive modes of risk management [3, 4, 6].

Presented comprehensive approach is based on the sequential use of three methods: FTA – fault tree analysis, HAZOP – Hazard and Operability study and FMEA – analysis [7, 8, 9].

COMPLEX OF QUALITY MANAGEMENT METHODS

Deeply structuring research of technical devices or process make the first step in the application of this approach. As a result, it is necessary to create hierarchical tree, describing the principal of work of your technical device functioning or your failure processes [5].

As a result of using this operators and ramified tree of events going down step by step, we have to reach the basic events changes of which can be estimated in it quantity, the managing of them determines the state of the technical device or the technological process [5]. During the construction of this tree, one should consider a few basic postulates. Firstly, it is important to respect hierarchy of preceding events during their construction; one "layer" events should be counted in one scale.

Secondly, in the course of constructing FTA tree it is important to use two operators – "AND" and "OR". These operators allow you to group the preceding events. If our failure depends of the further several failures we use "AND" operator. If the occurrence of a failure demands

failure in a single event, use the operator "OR".

Because of usage of these operators and branched events tree, moving level by level down it is necessary to reach the basic elements (events), changes in which makes quantifying in existing unit possible. Finally, at this stage of the research, elements, which control parameters and determine the status of the technical device or process throughout are obtained [1].

Next step will be use the HAZOP method for our facility. Using special control, words and systems for analyze of basic blocks (discovered with FTA) will provide characteristic for subprocesses and highlight collisions in them. HAZOP is based on "control word" expertise, which is a search for deviations from goals of the process.

Among different control words those are the most commonly used: "NO" – complete absence of the element or absence of it's functions (for example, if electrical circuit is down, then the lamp is down too); "MORE" – element has a value of more than it's limited too (high temperature, bigger dimensions of the item); "LOWER" – element has a value of less than it's expected to be (processing time is lower than expected, size of element is lower than it should be).

As a result of using two method shown above (Fig. 1) a fully-converged FTA tree were acquired, which represents all of the elements which affect on state of technical device and on the flow of the process. A HAZOP pivot table were also acquired, which represents relationship between elements of different level, their operating options in case of applying different control words.

In general, a representation created with those two methods shows us a detailed flow of any fails and errors inside the process or technical device. However, to transform this representation to a quality management tool we also need to use the third method – FMEA analysis.

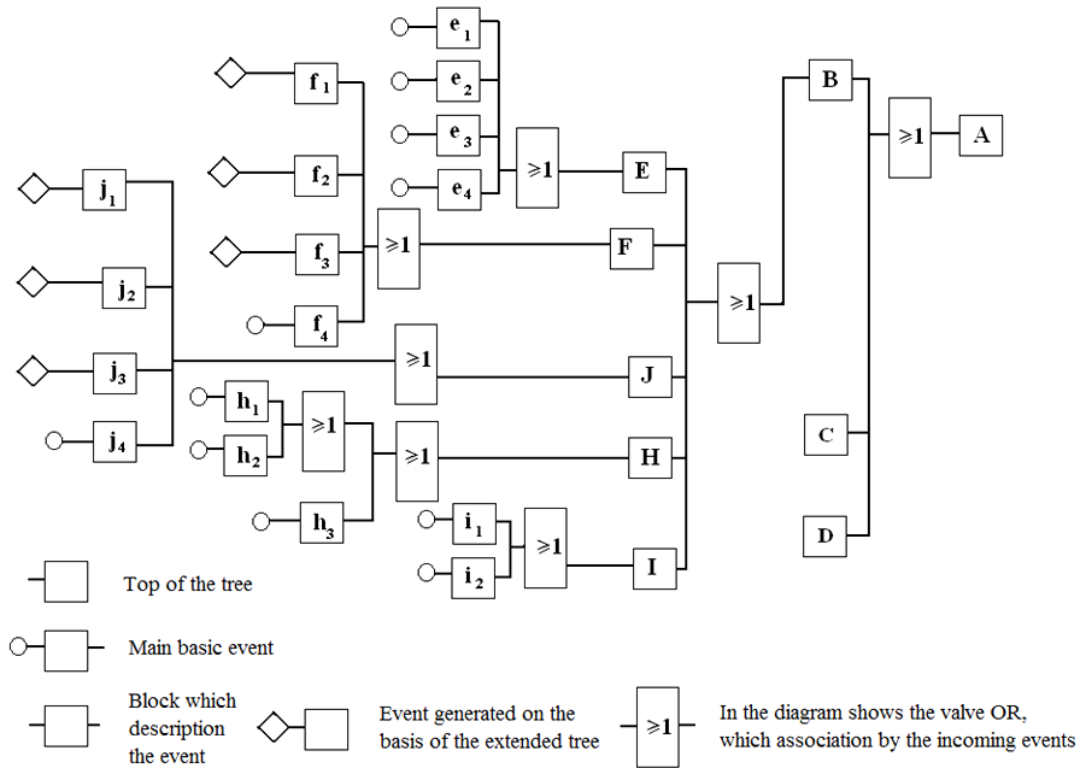

Fig. 1 Example of FTA – tree for process of manual arc welding of subsea pipeline:
A – The gap of weld of subsea oil pipeline; B – Unacceptable weld defects; C – critical effects of external conditions; D – an abnormality of functions of the pipeline system; E – The creation of weld defects due to misalignment of welded pipes; e₁ – misalignment of welded pipes; e₂ – Violation of the shell side of the gap; e₃ – Geometry violation of the cutting edges; e₄ – Violation of the fixation rigidity; F – The occurrence of defects in the first pass; J – The occurrence of defects during subsequent passes of welding; f₁, j₁ – Violation of welding mode; f₂, j₂ – Violation of environmental conditions; f₃, j₃ – Violation of quality of welding consumables; f₄, j₄ – Low qualification of personnel; H – The occurrence of defects during heat treatment; h₁ – temperature of the heat treatment of the weld; h₂ – The time of heat treatment; h₃ – Area of heat treatment; I – The emergence of defects during hydrotest; i₁ – Time of hydrotest; i₂ – pressure in the pipeline.

By grouping elements of FTA tree based on subprocesses, we will apply failure mode and effects analysis method (FMEA). First step in using this method is filling Table 1. On this step group of experts evaluates the following parameters based on a 10-level scale: S – severity, O – probability of occurring of failure, D – probability of diagnosing the failure. All of these parameters we should include in table [5]. Based on the following parameters we will calculate RPN of a priority risk number:

$$RPN = SOD \tag{1}$$

In case if during analysis RPN is higher than expected, then analyzed subprocess needed to be improved, using by using quality control tools. It is necessary to mention, that by this improved it is possible to lower rate of control and increase rate of diagnosing critical failure in a subprocess (Fig. 2).

However, seriously reflect on a severity of a failure is almost impossible. One of the most important things in FMEA is comparing limited risk number with a factual risk number. Results of this comparing allows to make a management decision on providing corrective work and also establish order which will be used to fix non perfect technological processes or elements of a technical device (Table 1).

Because for different technological processes and devices it is impossible to form a unified limited risk number, it's necessary for each case calculate risk number based on data from statistics and best practice. Optimal way is to relate limited risk number with a probability of failure occurrence in subprocess or element of the system [7].

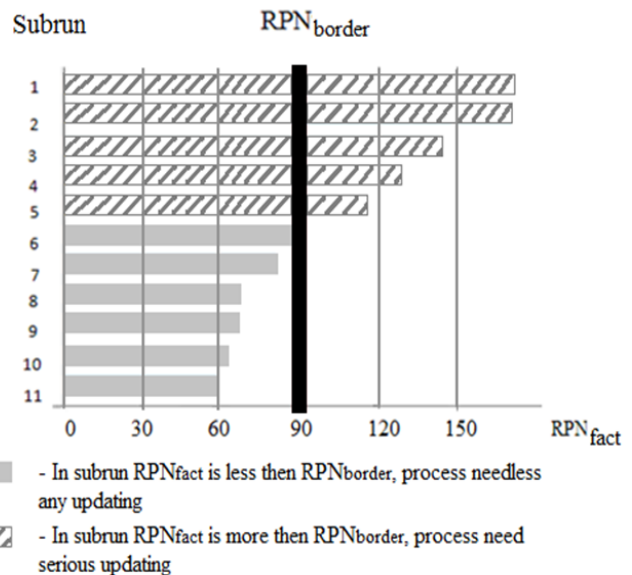

Fig. 2 Result of ranking sub welding processes by FMEA analysis:

- 1 – Operation of docking and centering of pipeline lashes into the sea, 2 – Welding of the root pass at the sea, 3 – Tack and welding of the weld root on land, 4 – Formation of pores during welding at the sea, 5 – Alignment errors during welding on land, 6 – Implementation of the final quality control, 7 – Formation of pores during welding on land, 8 – Preparation of pipes to sweep, 9 – Sweep of seams on the sea, 10 – Formation of slag during welding at the sea, 11 – Sweeping seams on land.

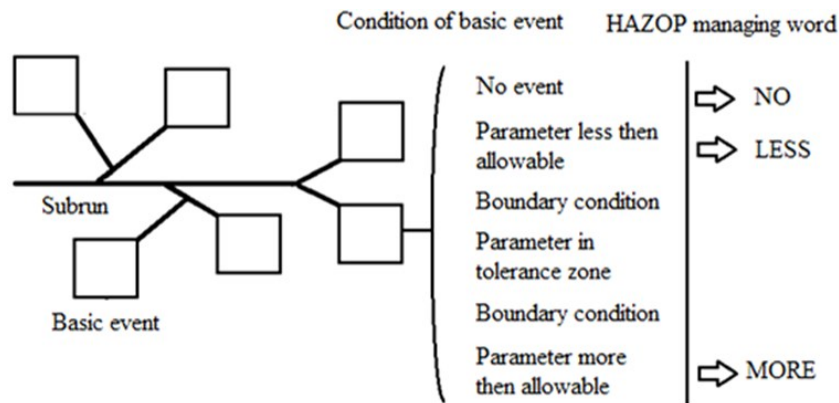

Fig. 3 Comparison of a range conditions of a basic event with the main managing words method HAZOP

Table 1
Table for FMEA analysis

| | |
|---|---|
| 1 | Process |
| 2 | Type of the potential defect |
| 3 | Consequences of potential defect |
| 4 | The severity and nature of the consequences S |
| 5 | The possible causes of emergence of discrepancies |
| 6 | Emergence O |
| 7 | Existing measures of detection |
| 8 | Detectability D |
| 9 | RPN |

Let's denote this group of modes as FHF (FTA-HAZOP-FMEA). Due to the usage of such row of modes of technological process we could reveal main subruns where some disparities could be made. In addition, this row of modes helps us to identify first causes of disparities and define risk level in each process. All of these make serious base for next dotted using of quality management instruments.

Nevertheless this approach have serious drawback because of HAZOP mode. At first, this HAZOP mode makes consistent estimation each of base events included in technological process. It makes this by using of iteration and application to each event all diversity of managing words. Such way makes plenty of low informative and doubling data. Secondly, these data mostly have evaluative type and they should be worked up by next using of expert mode (this step includes next stage of FHF row). Thirdly using of managing words from HAZOP vocabulary couldn't embrace some boundary conditions. Let's compare the list of manage words and different conditions of basic event. At figure 4 we can see, that HAZOP mode couldn't show either one or another element parameters when it is situated in boundary condition. That is why (by using requisitions of ISO 9000:2001) it is necessary to include in this FHF row mode such method which can directly fix and describe each parameter of subrun if it has some boundary condition.

MODERNIZATION OF AN INTEGRATED APPROACH OF QUALITY MANAGEMENT IN DIFFICULT TECHNICAL PROCESSES

Most optimal step in this case would be a betterment of this row approach by including of qualimetry mode – QM. Such combination of QM and HAZOP modes will help to itemize problem of making disparities and boundary conditions in each basic event. Any technological subrun consist

of different basic events row. Some of them could have calculated characteristic but the others couldn't. They have only quality information.

After construction of FTA-tree each of it's subrun branch have to be separate into two types of basic events (group of computational parameters and group of quality parameters), as a result of such separation and next expanded approach researcher could get much detailed data about system condition. In this case, most effective would be using of HAZOP mode for such events, which we couldn't research, by QM mode (Fig. 3).

QM mode is based on quantity detection between fact parameter data and basic parameter data. Only two variants of tolerance zone may exist for each parameter – bilateral or asymmetric [1].

Let's show two variants of mane parametric detection formula, depending of tolerance zone.

Detection of parameter in bilateral tolerance zone.

$$q_i = 1 - |(P_i - P_{\sigma i})| / 0,5T_i \tag{2}$$

where:

P_i – i- each single parameter (basic event) of researching subrun,

$P_{\sigma i}$ – nominal significance of each i- single parameter,

T_i – tolerance zone for each i- single parameter which is equal to difference between up and down levels of tolerance zone [2].

For parameter with asymmetric tolerance zone, we will have following formula:

$$q_i = 1 - \frac{|(P_i - P_{\sigma i})|}{T_i} \tag{3}$$

During the processing of QM data would be better to define ponderability of parameters and their deflections (we have analyzed previously) by using expert mode [2]. At the same time such relations should be carried out:

Also, we have to correlate dimension of deflections of each parameter with normative documents, regulating dimensions of these differences.

$$0 < m_i < 1 \quad \sum_{i=1}^n m_i = 1 \tag{4}$$

Then group of experts is to work out data for each subruns (which have been received by QM and HAZOP modes) and finally fix dimensions S, O, D for FMEA – mode. That is why we have to group and use correspondingly QM and HAZOP modes in cases when it is necessary and thus to improve FHF approach (Fig. 4).

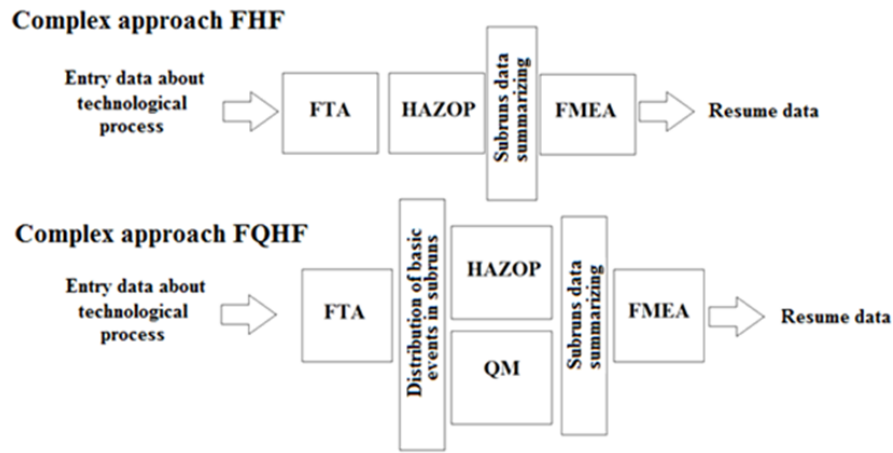

Fig. 4 Improvement of an integrated approach on quality management

CONCLUSION

Following the results of application of both methods, the expert group which is carrying out an assessment of the S, O, D parameters for the subsequent FMEA – the analysis, will possess more accurate and structured data that will allow to define more precisely, both boundary conditions, and boundary risk number. Thus advanced integrated approach on quality management of process of a construction of difficult technical objects will become more powerful tool providing the detailed subprocess and parametrical analysis. Defining of exact values of deviations with QM analyses will help us to make precise correction of different parameters of our technological process.

REFERENCES

- [1] V. Kershenbaum. Methods of quality control in engineering. Proc. Manual/ed. V. Kershenbaum, R. Khvastunova. M.: 1999, p. 212.
- [2] V. Nordin V. Practical methods for improving the quality of governance in the transport and service industries. Kaliningrad: BFU I. Kant, 2010, p. 212.
- [3] A. Skhirtladze, M. Kane. Systems, methods, and tools of quality management. St. Petersburg: Peter, 2009, p. 560.
- [4] N. Shichkov. "The choice of methods for measuring quality management system processes." Internet: <http://quality.eup.ru/DOCUM5/measuring-process.htm>.
- [5] P. Shcherban, V. Kershenbaum. "An integrated approach of using risk management techniques to the problem of quality control during the construction of an underwater pipeline." *Quality management in the oil and gas sector*, no 4, pp. 15-19, 2013.
- [6] M. Zasadzień. "Using the Pareto diagram and FMEA (Failure Mode and Effects Analysis) to identify key defects in a product." *Management Systems in Production Engineering*, no. 4(16), pp. 153-156, 2014. DOI 10.12914/MSPE-02-04-2014.
- [7] IEC 60812:2006. "Analysis techniques for system reliability – Procedure for failure mode and effects analysis (FMEA)". Switzerland, Geneva, second edition. 2006. p. 7.
- [8] IEC 61025:2006. "Fault tree analysis (FTA)", Switzerland, Geneva. Second edition, 2006. p. 103.
- [9] IEC 61882:2001. "Hazard and operability studies (HAZOP studies) – Application guide". Switzerland, Geneva. First edition, 2001. p. 11.

prof. dr inż. Victor Nordin
 Kaliningrad State Technical University
 PhD Pavel Shcherban
 Baltic Federal University of I. Kant
 ul. A. Newskiego 14, 236041 Kaliningrad, RUSSIA
 tel. +79521146697; +79622504751
 e-mail: nordin@gazinter.net
 ursa-maior@yandex.ru