

## THE CONCEPTUAL DESIGN ALGORITHM OF INLAND LNG BARGES

Dorota ŁOZOWICKA  
Maritime University of Szczecin  
Magdalena KAUP  
West Pomeranian University of Technology

### Abstract:

The article concerns the problem of inland waterways transport of LNG. Its aim is to present the algorithm of conceptual design of inland barges for LNG transport, intended for exploitation on European waterways. The article describes the areas where LNG barges exist, depending on the allowable operating parameters on the waterways. It presents existing architectural and construction solutions of barges for inland LNG transport, as well as the necessary equipment, due to the nature of cargo. Then the article presents the procedure of the conceptual design of LNG barges, including navigation restrictions and functional and economic criteria. The conceptual design algorithm of LNG barges, presented in the article, allows to preliminary design calculations, on the basis of which, are obtained the main dimensions and parameters of unit, depending on the transport task and the class of inland waterways, on which the transport will be realized.

**Key words:** inland shipping, LNG transport, conceptual design

### INTRODUCTION

The beginning of each design process is to define needs, the solution depends on its complexity and a range of conditions (internal and external). The area of acceptable solutions is dictated by imposed earlier indicators and criteria that will be governing stage solutions and the duration of the design process.

The needs of investors and society set further targets for the operation of the transport units as well as systems used on them (e.g. engine type, anchor system innovations, or navigation).

In the present day energy cooperation and integration of the gas systems of European countries generate the need for development of the means of transport of LNG. As far as maritime transport is an area widely known, in the case of transport by inland waterway requires other procedures design.

This is mainly due to the specificities of the inland waterways and their technical parameters. There are a few concepts of the barges for LNG transport, which can be used on inland waterways with high parameters. Taking under consideration the diversity of these parameters and the fact that in some countries, such as Poland, although there is a dense network of waterways, but with low parameters which impose additional restrictions. The desire to use this type of ships to transport LNG enforces to take into account the common all dependencies between waterways and the vessels, which will be operated in difficult conditions (small wide of the rivers, small radii of arcs or low parameters of hydraulic structures).

The aim of the article is to present a conceptual design algorithm of inland barges to transport LNG intended for

exploitation on European inland waterways with different parameters.

### DETERMINATION OF THE AREAS OF OPERATION OF THE INLAND WATERWAY FLEET TO LNG TRANSPORT

Natural system of waterways is the primary limitation of the possibility to transport of LNG to various collection points located in the hinterland. Often, the total construction of new sections of waterways is highly time- and expensive, therefore usually maintenance and modernization are mainly made. Major changes are only supplementing or improving the parameters of the existing waterways. In selected European countries there is a developed network of waterways and it has good conditions for navigation and shipping. This situation does not occur everywhere, therefore, it is impossible to implement the direct transport between European countries. Germany and the Netherlands are characterized by the highest level of transport work. In the years 2000-2013 growth of row 13-14% was reported, which is the result of the most extensive network of waterways [2]. These results indicate that, with appropriate financial expenses, restructuring and the competent use of the waterways, there is a real possibility of sustainable development, as in competition with other modes of transport.

Adopted the classification of inland waterways, which was approved by the United Nations Economic Commission and ECMT in 1992, includes the seven classes of the waterways-regional: I-III, of international importance: from IV onwards. Each class of waterways were assigned maximum parameters of ships, which may be operated. In practice, international shipping is carried out on the waterways of at least class IV, however, the carriage of LNG transport area

could be extended to a waterway of class III. However, this would require the development of the concept of ships that meet established criteria and would be to the existing local restrictions.

From the point of view of the design, the following waterways parameters influence for inland ships parameters [7]:

- transit depth ( $H_T$ ),
- the minimum depth guaranteed ( $H_{Gmin}$ ),
- operating depth ( $H_E$ ),
- the width of the waterway ( $B_W$ ),
- the radius of the arc of the waterway ( $R_W$ ),
- dimensions of the lock on the canal ( $L_L \times B_L \times H_L$ ),
- the smallest clearances under the bridges ( $A_H$ ).

Natural hydrological conditions and weather, as well as the condition of hydrotechnical structures occurring often make it difficult to conduct regular shipping. In addition, throughout the inland waterways network, the big problem is the diversity of technical characteristics and degrees of wear properties of hydraulic structures.

Operation of the inland waterway fleet to LNG transport is also determined by the location of inland ports, where LNG terminals are located. These terminals serve as distribution to end customers. They are equipped with specialized warehouses to store gas, cargo pump systems, etc. is

the efficiency on their territory or regasification operations. In the European Union there are more than 750 river ports, and some of them (about 40) serves as both the inland port and the sea. Ports in Germany, France and Belgium have the highest number of transshipments. In selected sea-river ports (eg. Rotterdam, Swinoujscie) LNG terminals are located, which are the source nodes for gas distribution system waterways inland. Terminal LNG at Zeebrugge (Belgium), and soon the terminal GATE on the Maasvlakte in Rotterdam are designed for loading LNG vessels. It is assumed the construction of LNG terminals along the Rhine and ensure the necessary equipment to carry out gas transport by inland waterways.

One of the important factors that may affect the areas of operation of the inland waterway transport of LNG is a project of the TEN-T network, namely:

- Meuse/Rhine-Main-Danube,
- Seine-Scheldt,
- Oder-Elbe Canal-Danube.

These connections can be the main corridors of the LNG distribution. Other waterways that connect these rivers can be used as a local distribution network.

Figure 1 shows the network of waterways in the Netherlands, Germany, Belgium, France, Poland and Romania.

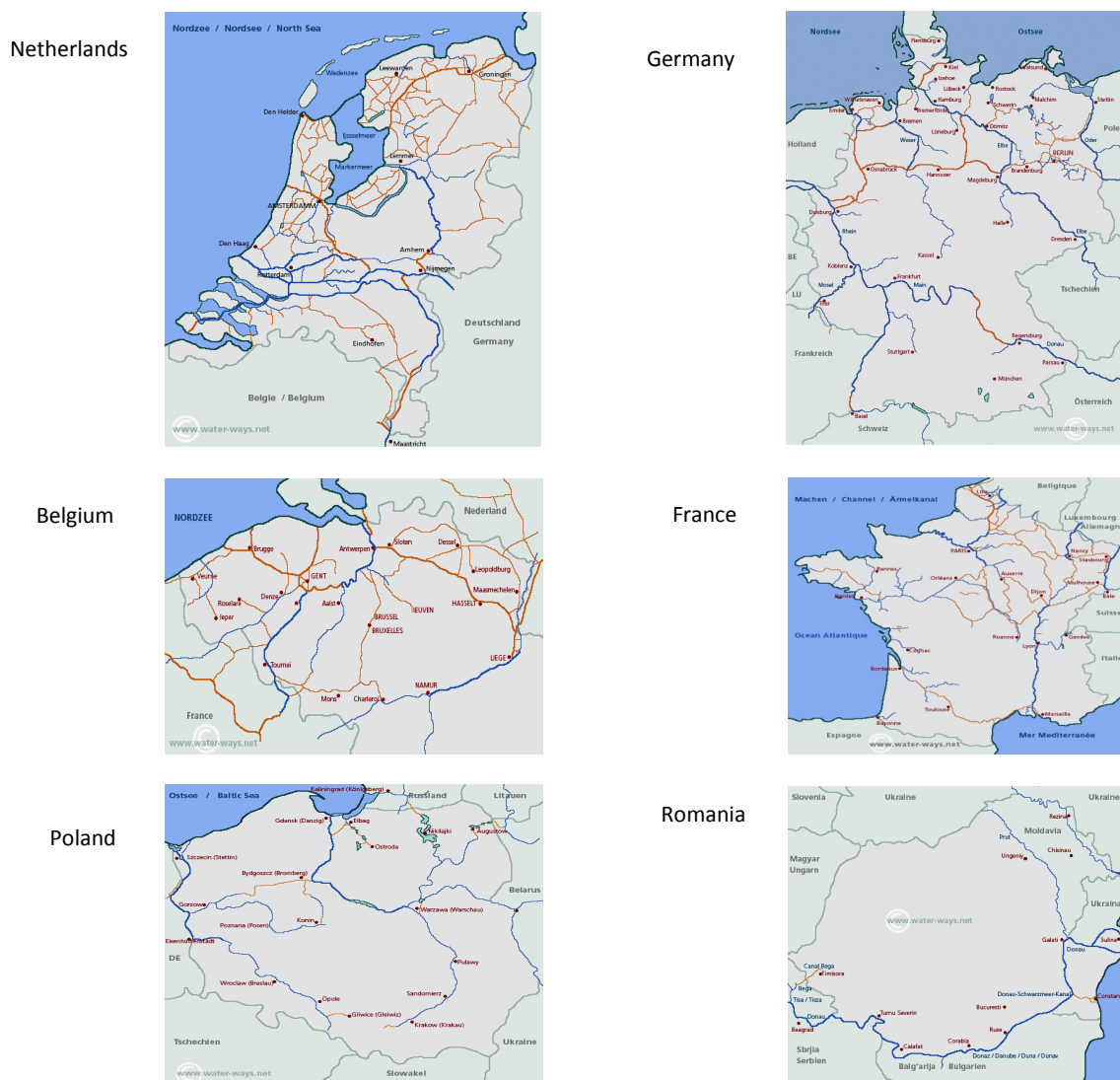

**Fig. 1 Inland waterways in selected European countries**  
 Source: [8].

Channel project Seine-Scheldt assumes the construction of 100 km of the waterway for vessels with a capacity of up to 4400 t. The channel connects the inland waterways and ports of France, Belgium, the Netherlands and Germany.

The Meuse design route/Rhine-Main-Danube Canal includes the waterways of Belgium, the Netherlands, Germany, Austria, Slovakia, Hungary, Croatia, Bulgaria and Romania, connecting the North Sea with the Black Sea.

For the countries of Central and Eastern Europe an important connection is the realization of the planned project the Elbe-Oder-Danube. Waterways will join Poland, the Czech Republic, Slovakia or Austria. Although this concept is not new, the huge costs of its implementation does not allow you to take radical action.

#### TYPE OF ARCHITECTURAL AND STRUCTURAL SOLUTIONS AND THE NECESSARY EQUIPMENT ON VESSELS FOR THE TRANSPORT OF LNG

In the design of the hull of the inland barge is distinguished by a double bottom and double sides, which shall perform the functions of strength and form secondary barrier (protection against leakage of the load to the environ-

ment), with the original barrier are the walls of the tank. The engine room is located in the aft section and separated from the cargo area protection by cofferdam. For security reasons, as well as strength conditions on vessels to transport LNG, cargo space is divided into tanks of varying design.

Because the load is transported in temperatures below  $-160^{\circ}\text{C}$  highly specialized vessels and equipment are required. There are following types of tanks: self-supporting tanks (spherical or prismatic) and embedded (diaphragm). In addition to this there is a possibility of placing on board or in the hull boat structurally independent tanks. They have a cylindrical shape. Another option are the twin tanks "bilobe". Their shape is the result of a merger of two cylindrical tanks, so obtained a larger capacity tank. Figure 2 shows the sections of the main types of tanks.

One of the Dutch shipyard "Veka" specializes in the construction of ships for the transport of LNG. The resulting projects inland units 9 (Fig. 3) assume the capacity of the gas tanks from  $2250\text{ m}^3$  to  $3000\text{ m}^3$ , with the length of the ship from the 86 m to 125 m [9].

Other solutions suggested "Jensen Maritime" (Fig. 4).

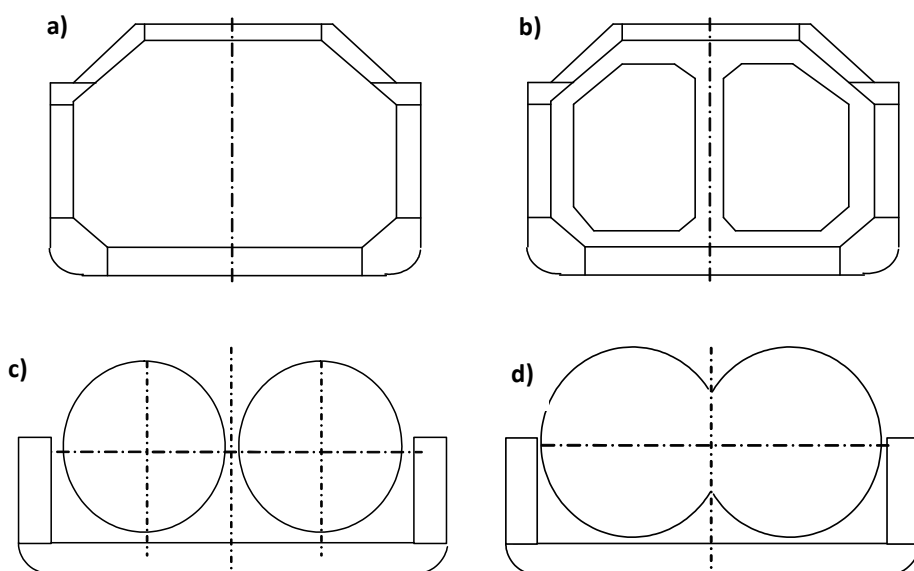

Fig. 2 Sections of LNG tanks:  
a) membrane, b) prismatic, c) spherical, d) type "bilobe"



Fig. 3 Inland waterways LNG unit designed by VEKA

Source: [9].



Fig. 4 Inland waterways LNG barge designed by Jensen Maritime

Source: [5].

One of the concepts is assumed putting tanks on board. This is a relevant solution in the absence of permanent gas streams, as the unit this can then be used for the transport of other cargo. In the case of the second concept of barges, tanks are placed partially below deck, as in the case of the concept of "Veka", so that the unit has a lower overall height and will have more range, to a lesser extent limited the height of cruising.

Due to the phenomenon of evaporation of gas (from approx. 0.1-0.2% per day), it is necessary to install its discharge from tanks. It can be liquefied and used as fuel for the main engine. The specifics of the cargo causes many renovation and repair applies to tanks and loading, and also the shorter is the life of a ship compared to others.

An important issue is to ensure the appropriate strength of such ships. This applies to both the fatigue strength, as well as the strength of the hull in the event of collision or stranding.

Vessels for the transport of LNG are equipped with unloading systems, which include high-performance loading pumps, measuring systems, etc.

The maximum volume of the cargo transported by inland waterway barges is determined by restriction of waterways, which in the first place, the limit of main dimensions i.e. the total length, width, draught, cruising height.

Depending on the existing parameters of the waterways and the present restrictions, due to functional criteria, environmental or economic, primarily different will be the size of the units and their type of architectural and design. Where is recommended the low draught and there are no limits to cruising height, the ships with horizontal cryogenic tanks on board or cryogenic containers can be operated. It is possible to place one container or tank in a row or two in several rows for the entire length of the ship can be placed.

The characteristics of such a solution is primarily a small draught, low weight and the possibility of using such ship for transport of containers or oversized cargos.

Vessels for the transport of LNG, which tanks are an integral part of the hull or part placed in the hull, will be characterized by greater capacity tanks, a larger amount of cruising and will require constant load streams of LNG.

Taking into account the fact, that inland ships for gas transport the return trip are pursuing without cargo, and also by various level of water (high, medium, low), it may be necessary to ballast them. It will provide the correct draught of ship, at high water.

### THE PROCEDURE DURING THE CONCEPTUAL DESIGN OF INLAND VESSEL TO LNG TRANSPORT

Conceptual design of transport units starts with the formulation of assumptions i.e. amount of cargo, ship speed and cruising range. Algorithm of design is used to obtain an acceptable solutions area, from the point of view of the objectives and characteristics of the solution in the space of solutions of maximum. The set of possible design solutions even in the case of the classic units is obtained [1].

Conceptual design process is determining the basic technical parameters of the ship in particular the length of the ship, its breadth, height, etc. [3, 4]. Variants of the hull shape are obtained after specifying the dimensions and parameters of the shape of the hull. It is important to verify compliance with the regulations regarding freeboard and buoyancy equations. Due to the type and features of the

ship are referred to limitations and criteria regarding the conditions and regimes of operation of ships.

From the point of view of economic the most important is the payback period and the size of the profit from the operation of the ship, or entire fleet.

International Code for the Construction and Equipment of Ships Carrying Liquefied Gases in Bulk. (IGC) and the rules of classification societies are the basic laws governing the design and construction of inland barges for the transport of LNG.

Conceptual design process starts from the identification of the technical requirements for operating the ship, and then perform a functional analysis. After taking into account any constraints and meet the requirements of the ship-owner, the main dimensions and parameters of the inland ship are referred [6]. The whole process of conceptual design can be divided into three stages:

Stage 1. Identification of design requirements and restrictions.

Stage 2. Parametric design and selection of dimensions.

Stage 3. The hull shape and spatial planning.

Identification of project tasks include clarifying the requirements of the ship-owner, the fixing of a common infrastructure and restrictions, analysis solutions, as well as to determine the classification rules.

Parametric design and selection of dimensions include the designation of the weight of the ship, the calculation the power of main engine and selection of main engine, as well as the calculation of freeboard.

Stage 3 covers the determination of the shape of the hull, the type of tanks and spatial planning of the ship. In addition, the preliminary economic analysis is carried out.

Figure 5 shows the algorithm for determining dimensions of waterway vessel to transport LNG.

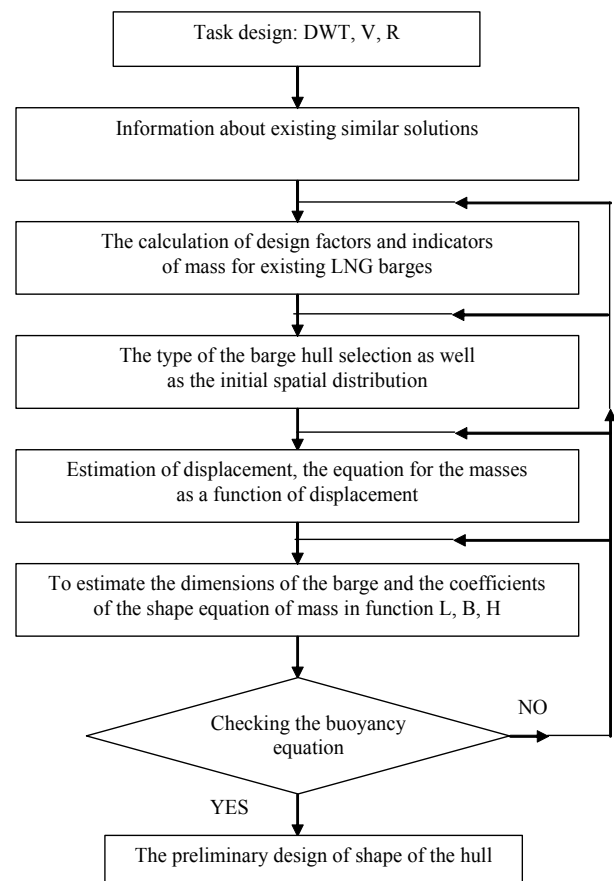

Fig. 5 Algorithm to estimate the dimensions of the barge LNG

Inland waterway infrastructure constraints are the largest group of constraints. They concern both infrastructure parameters and the possibility of inland ports and LNG terminals, and they impose horizontal dimensions of vessels. The length, width and draught of the vessel depends on the class of the inland waterway, the dimensions of buildings, hydraulic structures, radii meanders and the strength conditions. The height of the ship depends on the presence of overhead power lines and parameters bridges located along the waterway. Speed of unit depends on its parameters and parameters of the waterway. Increasing the speed or size of ship increases performance, but at the same time, increases resistance and the need for power. The higher the speed is the higher the fuel consumption and higher risk of contact between the bottom of the vessel from the bottom of the waterway.

The parameters of the cargo and ship size are important in the economic calculations. Volumetric parameters are the basis for the levying of charges for the services provided in a port and are the basis for charging channel, or using of the waterfront. Maximum capacitance parameters provides for the effective implementation of the transport and will affect the economic aspects of the operation of the unit [3, 4].

In accordance with the presented algorithm in technical task are defined three values:

- Capacity – DWT t,
- $V$  – speed km/h, and a cruising area-waterway on which the task will be carried out,
- $R$  – km.

Sought the dimensions and parameters of the vessel depend not only on the requirements of the ship-owner, but especially from those of infrastructure constraints.

Analysis of existing similar solutions allows for no coincidence the selection of dimensions and other characteristics, in order to start the iterative design process. At this stage the main dimensions are determined as follows:

- length over all –  $L_{ao}$  m,
- the length between perpendiculars –  $L_{pp}$  m,
- breadth –  $B$  m,
- height –  $H$  m,
- draft –  $T$  m,

as well as the main mass of the boat, including:

- mass of hull –  $M_k$  t,
- weight of engine room –  $M_s$  t,
- reserve of mass of light ship –  $M_r$  t,
- mass of light ship –  $P_s$  t.

In addition, the derived block coefficient of the barge,  $CB$  – and displacement ( $D$ ) t. The further procedure is presented in Figure 6.

After the initial evaluation of dimensions, it is necessary to check the stability of the barge in full operating status and the rolling period. In accordance with the International Convention on Load Lines (ICLL) the approximate freeboard,  $F_b$  m should be defined. The full review is not possible, because at this stage of the design, it is unknown its detailed shape and the applied technical solutions.

The next step is to set the power of main engine,  $N$  kW, because of its strong influence on the general characteristics of the barge (the main dimensions, volume). Designated the power of main engine is the basis for selection of the engine in the further stages of the project. According to the algorithms of the International Convention on Tonnage Measurement of Ships design capacity assessment is made

of the vessel-the gross and net. After the selection of the main machinery, equipment and the necessary systems and installation the preliminary plan and technical description is performed. Due to the nature of the barge of LNG, it is critical the right equipment in systems that provide safe and efficient transport of gas. Based on the presented in the article design algorithm, design calculations of barges to LNG transport can be performed.

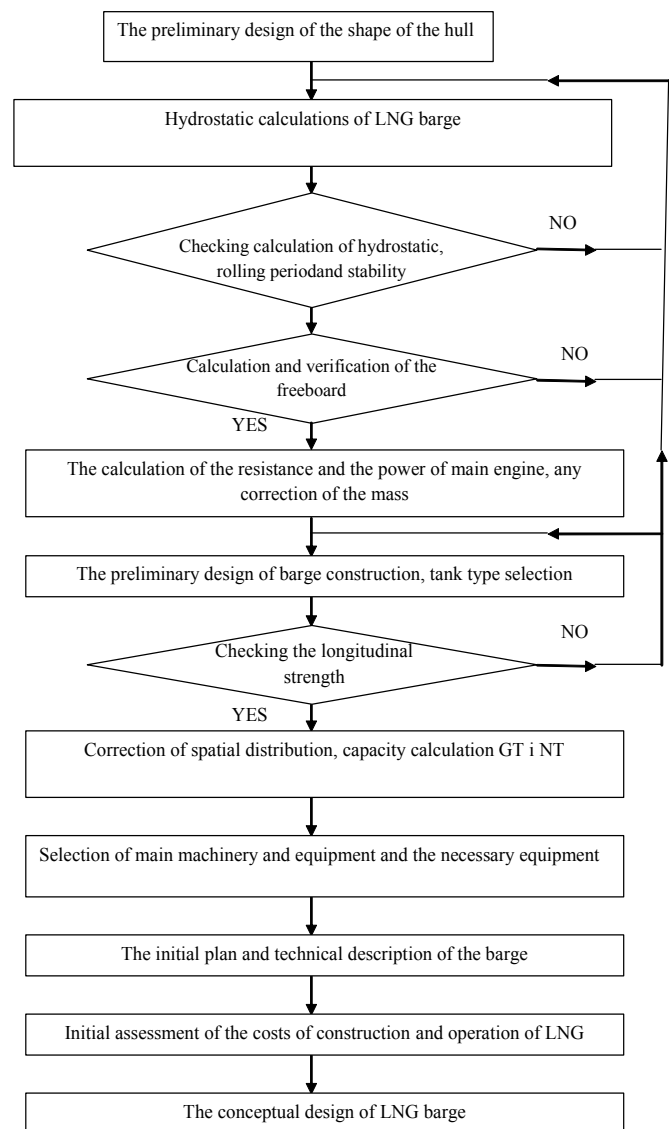

**Fig. 6 Hull shape and spatial layout of LNG barge determination algorithm**

## SUMMARY

The most important issue in the creation of the inland waterway fleet to transport LNG is adjusting the parameters of the construction to operational and technical considerations of waterways. This is due to the interdependencies between them and the waterways. Hydro meteorological conditions and existing parameters of waterways set specific operational and technical solutions of ships to the transport of LNG. Different design solutions depend on the functional and economic reasons, cruising range and, therefore, in one case, rational will be barges with tanks on board, and in another case with tanks in the hull.

The designation of the dimensions on the basis of the algorithm allows for variants of the barges to transport LNG, depending on the places of location of LNG terminals

and potential recipients, as well as the shipping conditions prevailing on inland waterways of class III and higher. Apply the algorithm allows to select the acceptable variants of solutions that meet the imposed limitations and criteria regarding the conditions and regimes of operation.

Creation of inland waterway fleet to transport LNG is consistent with current trends in transport development as well as the policy of the European Union concerning inland waterway transport.

#### REFERENCES

- [1] T. Abramowski. *Elementy multidyscyplinarnej optymalizacji wskaźników techniczno-ekonomicznych we wstępnym projektowaniu współbieżnym statków transportowych*, Szczecin: Wydawnictwo Uczelniane Zachodniopomorskiego Uniwersytetu Technologicznego w Szczecinie, 2011.
- [2] "EU Transport in Figures Statistical Pocketook 2015", in *Eurostat*, Luxembourg: Publications Office of the European Union, 2015.
- [3] M. Kaup. "Functional model of river-sea ships operating in European system of transport corridors. Part I. Methods used to elaborate functional models of river-sea ships operating in European system of transport corridors", *Polish Maritime Research*, no. 4(58), Vol 15, 2008, pp. 3-11.
- [4] M. Kaup. "Functional model of river-sea ships operating in European system of transport corridors. Part II. Methods of determination of design assumptions for river-sea ships operating in European system of transport corridors, according to their functional model", *Polish Maritime Research*, no. 3(57), Vol 15, 2008, pp. 3-11
- [5] W. Laursen. (2015). *Crowley Maritime Leads its Own LNG Revolution* [Online]. Available: <http://www.maritime-executive.com/article/crowley-leads-its-own-lng-revolution>
- [6] I. Semenov and K. Sanecka. *Teoria projektowania statków, Ćwiczenia projektowe*, Szczecin: Wydawnictwo PPH ZAPOL, 2001.
- [7] K. Wojewódzka-Król and R. Rolbiecki. *Teoria projektowania statków, Ćwiczenia projektowe*, Gdańsk: Wydawnictwo Uniwersytetu Gdańskiego, 2014.
- [8] *Europe's navigable waterways* (2016, May 18) [Online]. Available: <http://www.european-waterways.eu/>
- [9] *LNG Inland* (2016, May 18) [Online]. Available: [http://www.vekgroup.com/en/lng\\_inland.html](http://www.vekgroup.com/en/lng_inland.html)

---

dr inż. Dorota Łozowicka  
Maritime University of Szczecin, Faculty of Navigation  
ul. Wały Chrobrego 1-2, 70-500 Szczecin, POLAND  
e-mail: d.lozowicka@am.szczecin.pl  
dr inż. Magdalena Kaup  
West Pomeranian University of Technology Szczecin  
Faculty of Maritime Technology and Transport  
al. Piastów 41, 71-065 Szczecin, POLAND  
e-mail: mkaup@zut.edu.pl